

# AMBERGLO

## USER MANUAL



### **AmberGlo Electric Fireplace Suite with LED Effect Lights**

**AGL087 / AGL088**

Thank you for choosing this AmberGlo electric flame effect heater. Please read this guide, which aims to improve your understanding and appreciation of your new heater, and please retain it for future reference.

# CONTENTS

SAFETY	3
PARTS SUPPLIED	7
PRODUCT DIAGRAM	8
INSTALLATION	9
OPERATION	10
SETTING UP THE SMART APP	12
USING THE SMART APP	15
CARE AND MAINTENANCE	21
BATTERY INFORMATION	21
TROUBLESHOOTING	22
SUPPORT	24
TECHNICAL DATA	24
PSTI STATEMENT AND DECLARATION OF CONFORMITY	26

## SAFETY INFORMATION

When using electrical appliances, basic safety precautions should always be followed, including the following:



- **IMPORTANT:** Read all instructions and warnings carefully before starting installation. Failure to follow these instructions may result in a possible electric shock or fire hazard and will void the warranty.
- Before connecting the appliance, be sure that the mains voltage available matches that specified on the rating plate, and that the outlet is suitably grounded.
- The appliance must be installed in a place which is in line with national regulations concerning the discharge of air.
- Do not cut, notch or damage any joist, beam or rafter when installing the appliance.
- This appliance can be used by children aged from 8 years and above and persons with reduced physical, sensory, or mental capabilities or lack of experience and knowledge if they have been given supervision or instruction concerning the use of the appliance in a safe way and understand the hazards involved.
- Children aged 3 and under shall only switch on/off the appliance provided that it has been placed or installed in its intended normal operating position, they have been given supervision or instruction concerning the safe use of the appliance, and they understand the hazards involved. Children aged 3 and under shall not plug in, regulate, clean, or perform user maintenance on the appliance
- Children under 3 years should be kept away unless continuously supervised.
- Some parts of this product can become very hot and cause burns. Particular attention has to be given where children and vulnerable people are present.
- If the supply cord is damaged, it must be replaced by the manufacturer, its service agent, or a similarly qualified person in order to avoid a hazard.
- **WARNING:** In order to avoid overheating, do not cover the heater.
- The heater must not be located immediately below a socket outlet.
- **CAUTION:** In order to avoid a hazard due to the inadvertent resetting of the thermal cut-out, this appliance must not be supplied through an external switching device, such as a timer, or connected to a circuit that is regularly switched on and off by the utility.
- Do not attempt to repair, disassemble, or modify the appliance. This unit contains no user-serviceable parts.
- Ensure the plug is accessible after installation to disconnect the unit from all power.
- Always unplug or disconnect the appliance from the mains power supply when not in use or when moving or cleaning it. Do not pull the cord to unplug the heater.
- Keep the heater clean. Do not allow any object to enter the ventilation or exhaust opening, as this may cause electric shock, fire, or damage to the heater.
- Do not use the appliance for other than its intended use. It is designed for domestic indoor use only.
- There may be a trace of odour during the first few minutes of initial use or after a storage period. This is normal and will quickly disappear.
- If the glass is damaged, do not use the heater in order to avoid a hazard.
- Avoid the use of an extension cord, as the cord may overheat and cause a risk of fire.
- This fireplace is hot when in use. To avoid burns, do not let bare skin touch exposed hot surfaces.
- Keep combustible materials, such as furniture, pillows, bedding, papers, clothes, and curtains, at least 1 metre from the front and sides of this appliance.

- This appliance is designed for indoor use only and is not intended for use in bathrooms, laundry areas and similar indoor locations. Never locate this appliance where it may become exposed to water.
- Do not place this fire directly onto a carpeted surface to avoid discolouration due to heat. The fireplace may only be positioned on a carpet if the carpet is carefully cut around the base to ensure safe and stable placement.
- Do not run the power cable under carpeting. Do not cover the cord with throw rugs, runners, or the like. Ensure the cord is kept away from traffic areas and kept in a position which would not present a trip hazard when positioning it during installation.
- To disconnect this appliance, press the On/Off button to turn it off, then remove the plug from the outlet.
- This appliance has hot and arching or sparking parts inside. Do not use it in areas where gasoline, paint, or any flammable liquids are used or stored.
- This appliance should not be used as a drying rack for clothing, nor should Christmas stockings or decorations be hung on or near it.
- This electric fire is an instant heat source to warm up a room and is great for visual room ambience; it doesn't necessarily need to be used as a constant or permanent source of heating for the home.
- If a television or other electrical device is above this fireplace, the installers must ensure that the ambient temperature around the television does not exceed manufacturers' recommendations.
- Clean the fire regularly to prevent the build-up of hairs, dust, or lint around the fire, as this may cause the outlet to become blocked.
- Do not use aerosols or steam cleaners on or around the fire.
- The fire should be tested before installation.
- We always recommend employing an experienced, qualified installer when fitting such products. Each installation will vary, and specialist expertise is often required to conduct the necessary building work. The manufacturer bears no responsibility or liability for any poor workmanship or incorrectly installed fires and/or fireplaces.

## **Manual Handling**

- The heater must not be moved while in use. Please allow a suitable amount of time for the unit to cool before attempting to move it.
- One person should be sufficient to lift the heater. If, for any reason, it is considered too heavy, then obtain assistance.
- When lifting, always keep your back straight. Bend your legs and not your back.
- Avoid twisting at the waist. It is better to reposition your feet.
- Avoid upper body / top heavy bending. Always bend from the knees rather than the waist. Do not lean forward or sideways whilst handling the heater.
- Always grip with the palm of the hand. Do not use the tips of your fingers for support.
- Always keep the heater as close to the body as possible. This will minimise the cantilever action.
- If required, use gloves to provide additional grip.
- Always use assistance if required.

## BATTERY WARNINGS

 	<p style="text-align: center;"><b>BATTERY WARNING</b></p> <p><b>KEEP OUT OF REACH OF CHILDREN</b> Swallowing can lead to chemical burns, perforation of soft tissue, and death. Severe burns can occur within 2 hours of ingestion. Seek medical attention immediately.</p>	
<ul style="list-style-type: none"><li>• If the battery compartment (if applicable) does not close securely, stop using the product and keep it away from children.</li><li>• If you think batteries might have been swallowed, or placed inside any part of the body, seek immediate medical attention</li></ul>		
<p style="text-align: center;"><b>THERE MAY BE NO OBVIOUS SYMPTOMS OF BATTERY INGESTION</b></p>		
<p>Unfortunately, it is not obvious when a button or coin battery is stuck in a child's oesophagus (food pipe). There are no specific symptoms associated with this. The child might:</p> <ul style="list-style-type: none"><li>• Cough, gag or drool a lot;</li><li>• Appear to have a stomach upset or a virus;</li><li>• Be sick;</li><li>• Point to their throat or stomach;</li><li>• Have a pain in their abdomen, chest or throat;</li><li>• Be tired or lethargic;</li><li>• Be quieter or more clingy than usual or otherwise "not themselves";</li><li>• Lose their appetite or have a reduced appetite; and</li><li>• Not want to eat solid food / be unable to eat solid food.</li></ul> <p>These sorts of symptoms vary or fluctuate, with the pain increasing and then subsiding.</p> <p>A specific symptom to button and coin battery ingestion is vomiting fresh (bright red) blood. If the child does this seek immediate medical help.</p> <p>The lack of clear symptoms is why it is important to be vigilant with "flat" or spare button or coin batteries in the home and the products that contain them.</p>		

## ELECTRICAL SAFETY

The heater must not be located under an electrical socket; the socket must always be accessible in order to disconnect the heater from the electrical supply for maintenance and cleaning.

### IMPORTANT:

- This heater must be earthed. The mains supply must be safely routed from the heater to an electrical socket from the heater.
- If the supply cord is damaged, it must be replaced by the manufacturer, service agent, or a similarly qualified person to avoid a hazard.

This appliance is supplied with a BS1363 3-pin plug fitted with a 13-amp fuse. If the fuse requires replacement, it must be replaced with a fuse rated at 13 Amps and approved to BS1362.

In the event the mains plug has to be removed or replaced for any reason, please reference the below:

**NOTE:** The wires in the mains lead on this appliance are coloured in accordance with the following code:

Green and Yellow - Earth  
Blue - Neutral  
Brown - Live

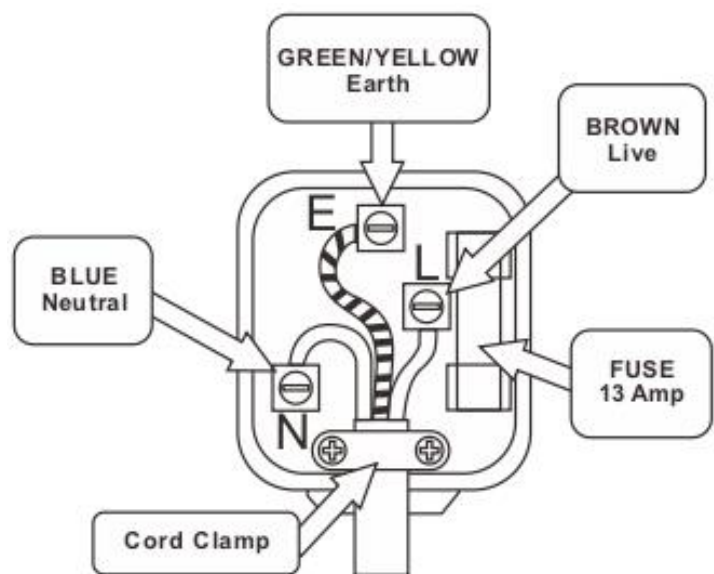





If the wires do not match the colour coding above, please follow the below.

- The green and yellow wire must be connected to the terminal, which is marked with the letter E or with the earth symbol  $\perp$ . This colouring will not change.
- The blue wire may be black and must be connected to the terminal marked N.
- The brown wire may be red and must be connected to the terminal marked L.

**IMPORTANT:** Any cut-off plug should be disposed of safely to prevent a hazard. There is a danger of electric shock if a cut-off plug is inserted into a socket outlet.

## PARTS SUPPLIED

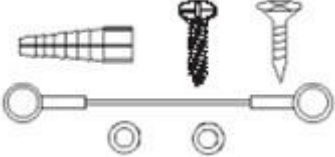
REF NO	DESCRIPTION	QTY
A		1 SET
B		1 SET
C		1
D		2
E		1

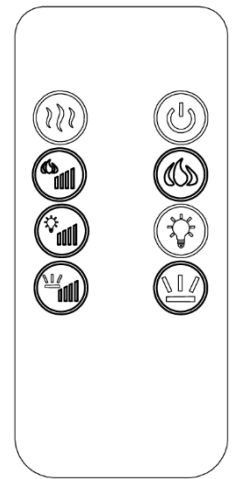

Remote

**PLEASE NOTE:** Some parts are packaged within the cavity of the surround on the rear of the fire.

### BEFORE USE!

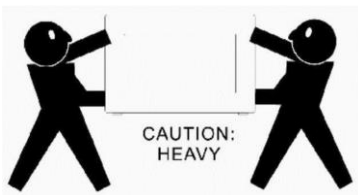

Before using the appliance for the first time, ensure that it has been fully unpacked and that all packaging has been disposed of properly to ensure it does not present a risk to children or animals.

Due to the size and weight of the fire, we would advise two people to carry out the installation to prevent injury or damage.

### RF EXPOSURE GUIDELINES

**IMPORTANT!** To meet RF (Radiofrequency) exposure requirements:

1. A minimum separation distance of 20 cm must be maintained between the device and individuals during operation.
2. Operating the device closer than this distance is not recommended.
3. The antenna used for this transmitter must not be co-located or operated in conjunction with any other antenna or transmitter.

# PRODUCT DIAGRAMS

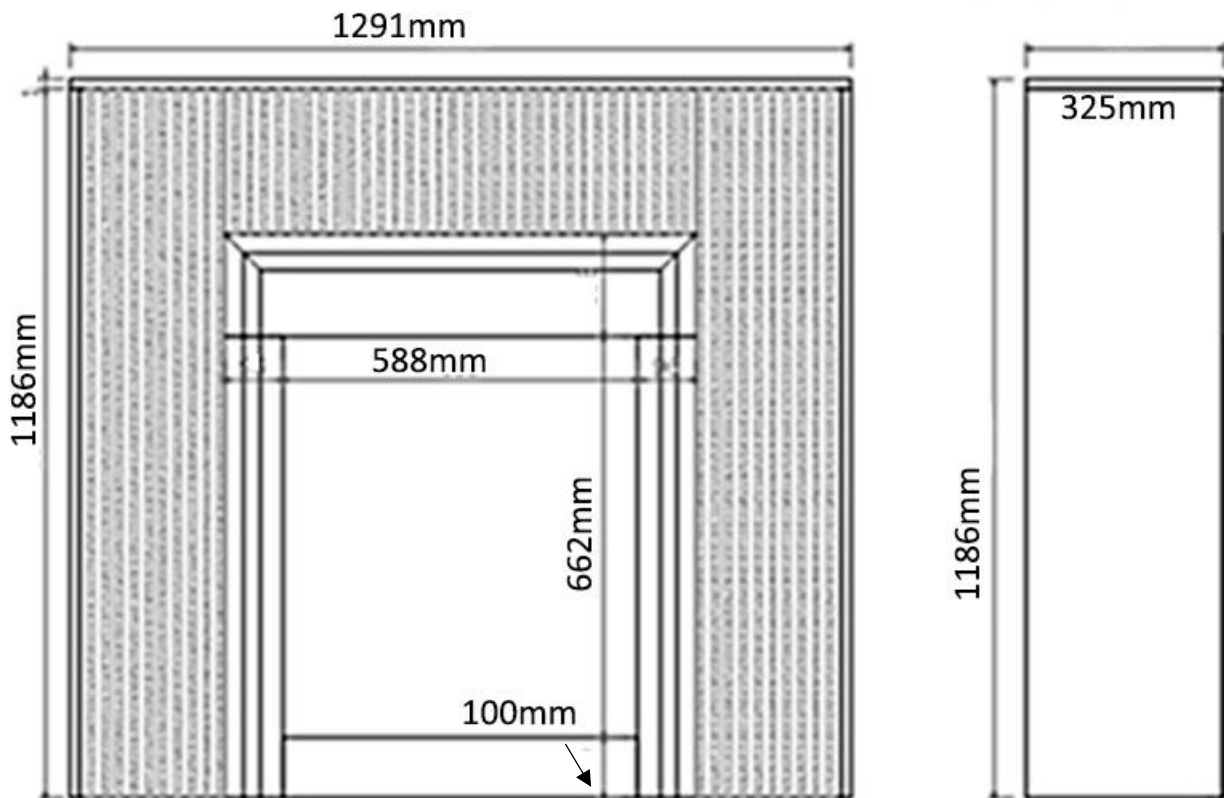
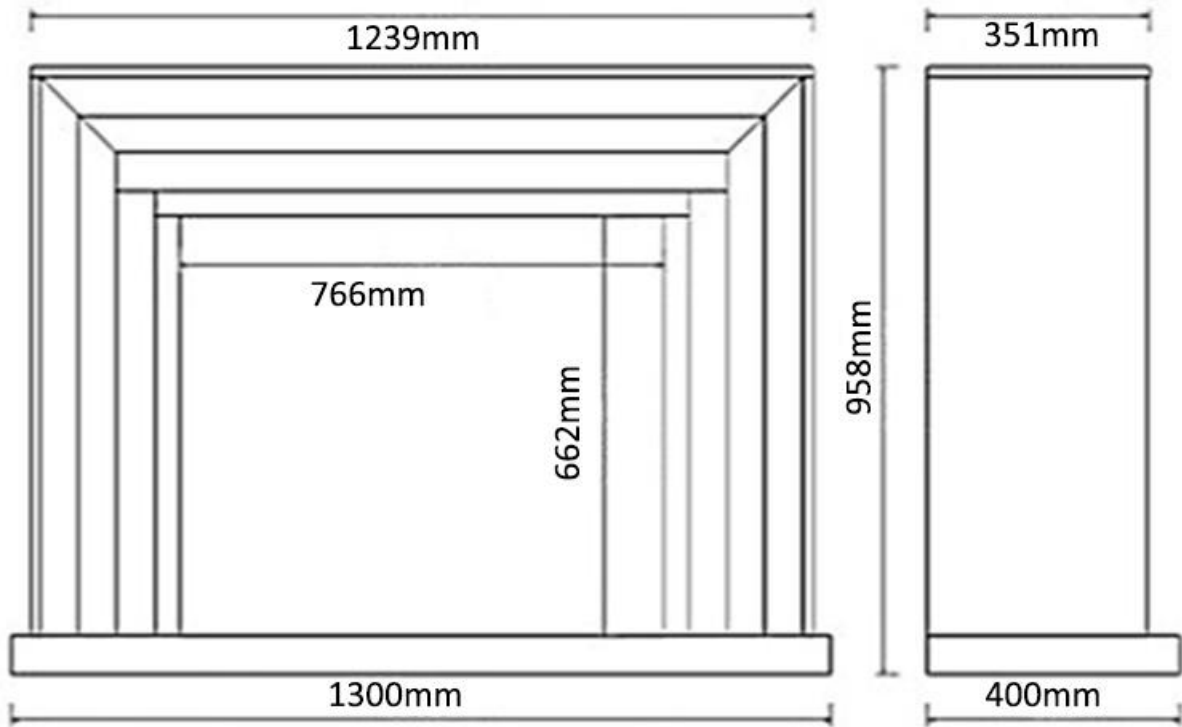





## SETTING UP THE WALL ANCHORS

It is strongly recommended that a wall anchor safety cable be used to reduce the risk of the fireplace tipping over accidentally.

**WARNING:** The safety cable may reduce the risk of injury if the fireplace is improperly handled, but it is not a substitute for proper adult supervision. Children should never be left unattended near any heater.

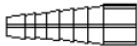
**IMPORTANT:** The screws and wall plugs provided are suitable for masonry walls only. For other wall types (e.g. drywall, plasterboard, or stud walls), use appropriate fixings as advised by a qualified installer.

1. Drill a 5/16" (8 mm) hole into the wall at the desired anchor location.
2. Insert the plastic wall anchor (TR1) into the hole and gently tap it until the flange is flush with the wall surface.
3. Position the fireplace or mantel close to the wall.
4. Secure one end of the safety cable (TR4) to the back of the fireplace mantel using:
  - a. One furniture anchor screw (TR3), and
  - b. One washer (TR5).
5. Attach the other end of the safety cable to the wall anchor using:
  - a. One wall anchor screw (TR2), and
  - b. One washer (TR5).
6. Ensure all screws are tightened securely.

TR1		Wall anchor
TR2		Wall anchor screw
TR3		Furniture anchor screw
TR4		Safety cable
TR5		Washers

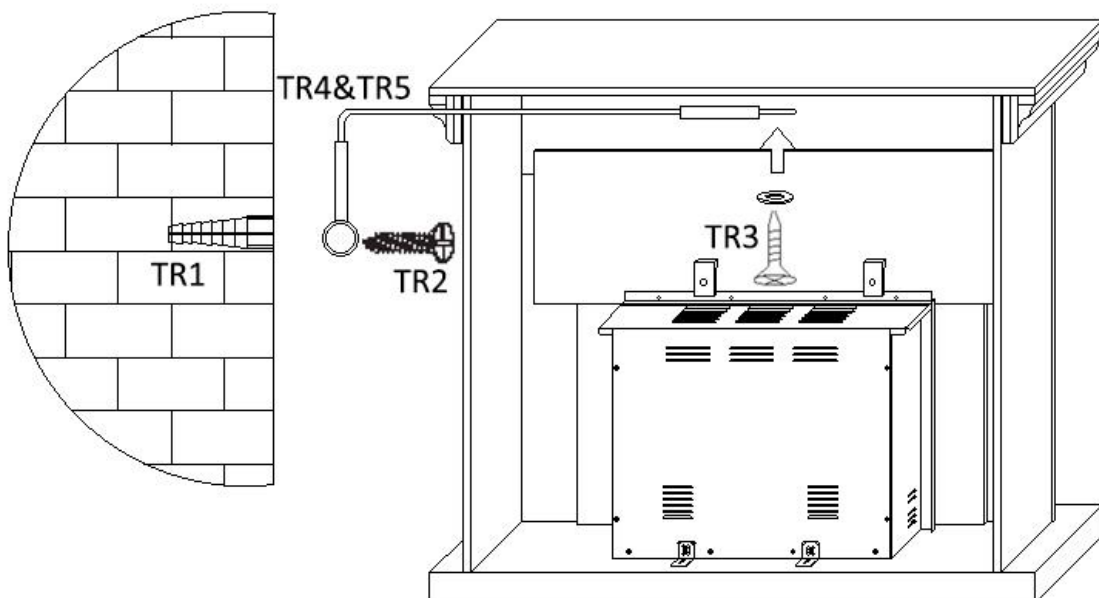

## INSTALLATION INSTRUCTIONS

1. Place your fire in your desired location, ensuring ample room for ventilation on all sides.
2. Attach the two suction cups to the glass, pull down and tilt the glass to remove it from the fire. Place the glass onto a soft blanket to avoid breakage or scratching.

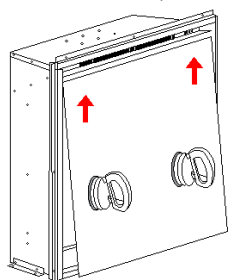
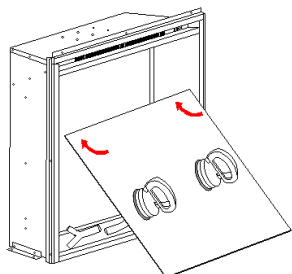

3. Insert the logs and pebbles into the bed in your desired design.
4. Carefully lift the glass again with the suction cups.
5. Then tilt the top of the glass towards the top of the fire and insert.
6. Once the top is in place, slot the glass into the bottom of the fire.
7. Plug in your heater and ensure the wire will not be trapped or crushed.

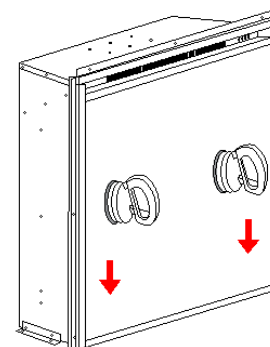
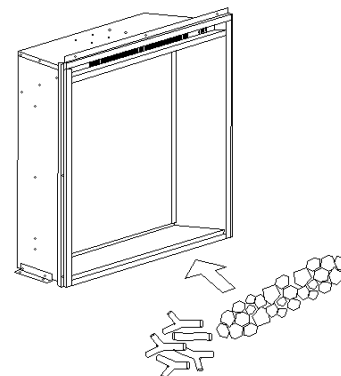



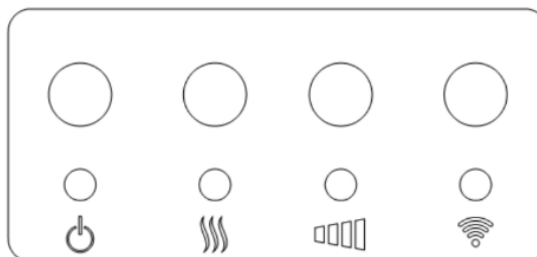





## OPERATION



FUNCTION	IMAGE	DESCRIPTION
POWER		Press the power button to switch the unit on. The indicator light will illuminate, and you can then select the desired function. Press again to turn off the heater and enter standby mode.
HEAT FUNCTION		Press this button to activate the heat function. Press again to turn it off. <b>NOTE:</b> After the heating mode is turned off, the fan will continue to run for approximately 30 seconds before shutting down. This is a normal part of the appliance's cooling process and does not indicate a fault.
FLAME EFFECT		Press this button to cycle through six brightness settings for the flame effect, from level 0 (off) to level 5 (brightest). Level 1 is the dimmest setting.
WIFI		The smart remote is the 'Tuya' app. For setup and usage instructions, please refer to the 'Setting up the App' section. <b>NOTE:</b> If the appliance is turned off using the physical power button on the unit, the Wi-Fi button must be pressed again upon powering the unit back on to restore Wi-Fi connectivity. This step is not required when the appliance is turned off via the smart app.

## REMOTE CONTROL

FUNCTION	IMAGE	DESCRIPTION
<b>POWER</b>		Press the power button to switch the unit on. Press again to turn it off and enter standby mode.
<b>HEAT FUNCTION</b>		Press this button to activate the heater. Press again to turn it off.
<b>COLOUR EFFECT</b>		Press this button to change the flame colour. The unit offers seven flame colour options. C1: red+yellow+blue      C5: blue C2: red+blue                C6: red C3: yellow+blue            C7: yellow C4: red+yellow
<b>FLAME EFFECT</b>		Press this button to cycle through six brightness settings for the flame effect, from level 0 (off) to level 5 (brightest). Level 1 is the dimmest setting.
<b>TOP LIGHT COLOUR EFFECT</b>		Press this button to change the colour of the top light flame effect. Ten colour options are available. C1: red                        C6: baby blue C2: blue                      C7: purple C3: deep green              C8: baby green C4: pink                      C9: sky blue C5: yellow                  C10: baby purple
<b>TOP LIGHT FLAME EFFECT</b>		Press this button to cycle through six brightness settings for the top light, from level 0 (off) to level 5 (brightest). Level 1 is the dimmest setting.
<b>CARBON BED COLOUR EFFECT</b>		Press this button to change the colour of the carbon bed flame effect. Ten colour options are available. C1: red                        C6: baby blue C2: blue                      C7: white+purple C3: green                    C8: baby green C4: purple                    C9: white+blue C5: pale green              C10: gradient colour
<b>CARBON BED FLAME EFFECT</b>		Press this button to cycle through six brightness settings for the carbon bed flame effect, from level 0 (off) to level 5 (brightest). Level 1 is the dimmest setting.

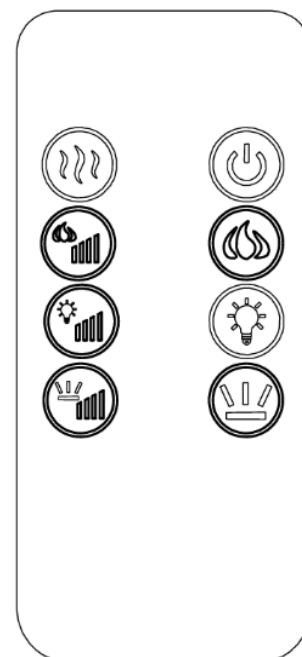

# SETTING UP THE SMART APP

## DOWNLOADING THE APP

**NOTE:** The images in this manual are for illustration purposes only. The app is subject to updates, and its interface may change over time.

There are three ways to download the Tuya Smart app:

1. Open your phone browser and go to [smartapp.tuya.com/tuyasmart](https://smartapp.tuya.com/tuyasmart). Select your country and press **Download**.
2. Search for **Tuya Smart** in the Apple App Store (iOS) or Google Play Store (Android). Look for the QR icon for reference.
3. Scan the following QR code to be directed to the download page.



## REGISTERING ON THE APP

1. Open the app, read the User Agreement & Privacy Policy, and press **Agree**.
2. On the login screen, select **Sign Up**.
3. Select your country and enter your email address.
4. Tick the box to **agree to the terms and conditions**.
5. Press **Get Verification Code**.
6. Check your email inbox and enter the six-digit code in the app.
7. Set a password (6 to 20 characters, including letters and numbers).
8. Select or deselect Service Maintenance & Improvement Activity and Personalised Recommendations based on your preference.
9. Press **Go to App**. You will now be taken to the Tuya Smart home screen.

**NOTE:** After signing in to the Tuya Smart app for the first time, a pop-up message may appear on the home screen. Follow the on-screen instructions if you wish to enable or access additional features for the home screen.

## SETTING UP THE WI-FI (2.4GHZ CONNECTION)

**NOTE:** If you are unsure about your router settings, contact your **internet provider** for assistance. To connect the unit via Wi-Fi, ensure your router supports **dual-band Wi-Fi** (2.4GHz and 5GHz) and that the 2.4GHz band is available. You can check this in one of the following ways:

1. **If your router already has a 2.4GHz network**, temporarily disable the 5GHz band while setting up the unit. You may re-enable it after setup.
2. **If your router does not have a separate 2.4GHz network**, enable it through your router settings:
  - Open a web browser and enter your router's **IP address** (found on the back of your router).
  - Login to your router settings and look for Wi-Fi or network settings.
  - Follow your provider's instructions to enable 2.4GHz Wi-Fi.
3. **Alternatively, contact your internet provider** to assist with enabling 2.4GHz Wi-Fi. Once the 2.4GHz network is enabled, connect your phone to it before setting up the unit.

## BEFORE YOU START

- Place the unit **close to the router** during initial setup.
- Ensure the unit remains **within range of the Wi-Fi signal** for normal operation.
- Please note that all app images and diagrams are solely for illustrational purposes as it is subject to continual improvement and further updates.

## SETTING UP YOUR HOME WITHIN THE APP

TUYA is designed to work with many compatible smart devices within your home and multiple devices within different houses. As such, during the setup process, the app requires that different areas be created and named to allow easy management of all your devices. When added, devices are assigned to one of the rooms you created.

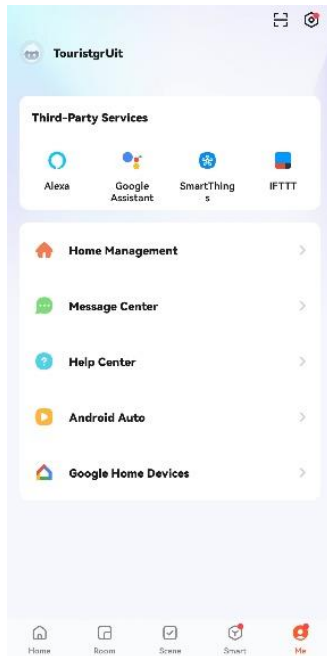

### TO CREATE A HOME

1. Press **Me** on the bottom right of the Home screen.
2. Press **Home Management**, then **Create a Home** button.
3. Type in a name for your home
4. Press the **location button** to select the location of your home. (See **SETTING YOUR LOCATION** below)
5. New rooms can be added by pressing the **Add another room** option at the bottom.
6. Untick any rooms that are not required on the app.
7. Press **Done** in the top right corner.

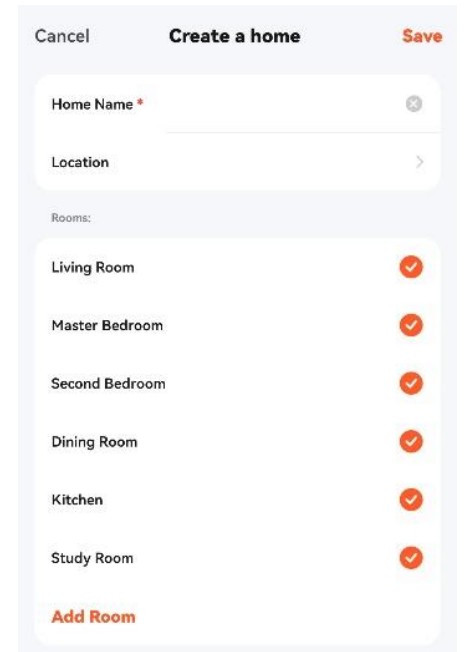

### SETTING YOUR LOCATION

Use your finger to move the orange **Home** symbol. When the symbol is in the approximate location of your home, press the **confirm** button in the top right corner.

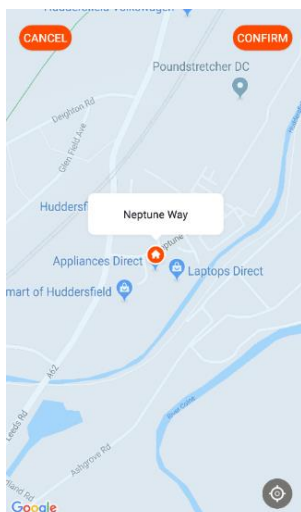





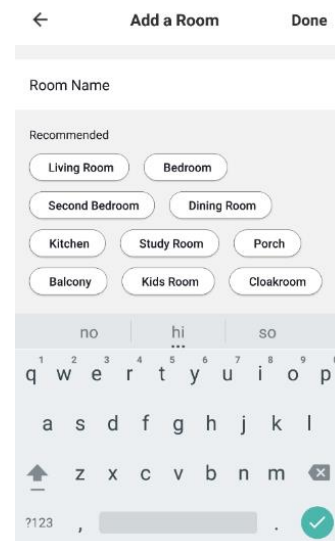



### ADD ANOTHER ROOM

Type in the room's name and press **Done** in the top right corner.

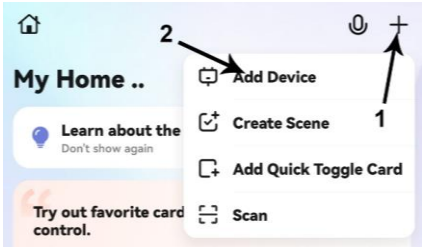
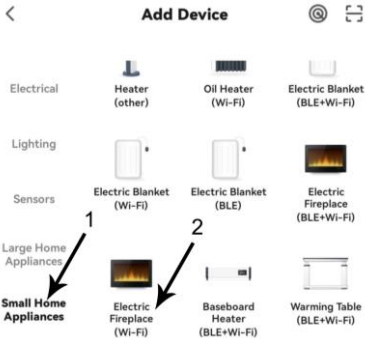
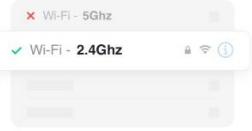

# PAIRING THE APPLIANCE VIA WIFI CONNECTION

Before initiating the connection, ensure the Wi-Fi indicator rapidly blinks. Press the Wi-Fi button  to power the module on or off. Press the Wi-Fi button  again to enter pairing mode. The indicator light will flash rapidly while attempting automatic connection. Also, ensure your phone is connected to the Wi-Fi network. (We advise turning mobile data off during setup.)

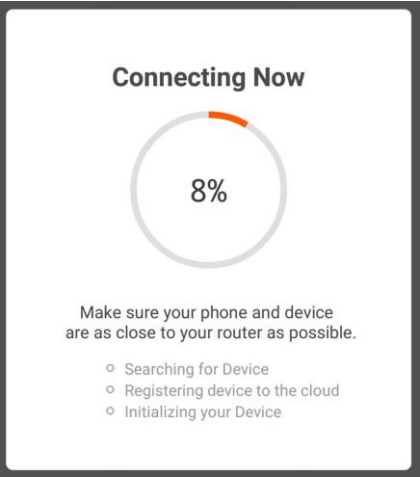
<p>1. Open app and press “+” to add device, or use the add device button</p> 	<p>2. Select the type of device as “Electric Fireplace (Wi-Fi)” within the Home Appliance tab.</p> 	<p>3. Enter your Wi-Fi password and press confirm.</p> <p>Select 2.4 GHz Wi-Fi Network and enter password.</p> <p>If your Wi-Fi is 5GHz, please set it to be 2.4GHz. <a href="#">Common router setting method</a></p>  <p>1  [Your 2.4Ghz network]</p> <p>2  Password [Your wifi password]</p> <p>3 </p>
<p>4. Press on the orange button at the bottom of the screen.</p> <p>×</p> <p><b>Reset the device</b></p>  <p>Press and hold the RESET button for 5 seconds until the indicator blinks (subject to the user manual).</p> <p>1</p> <p></p> <p><a href="#">Reset Device Step by Step</a></p>	<p>5. This will then transfer the settings to the heater. Wait for this to complete. If this fails, retry.</p> 	

# CONTROLLING YOUR APPLIANCE THROUGH THE APP

## THE HOME SCREEN

**NOTE:** Due to the continuous development of the app, the layout and available features may be subject to change.

Each device has its own entry on the home screen to allow the user to either quickly turn the unit on or off or to enter the device screen to make other changes.

**Voice Control:** Press to give verbal instructions for operation.

**Add Device:** Add a device to the app and go through the setup process.

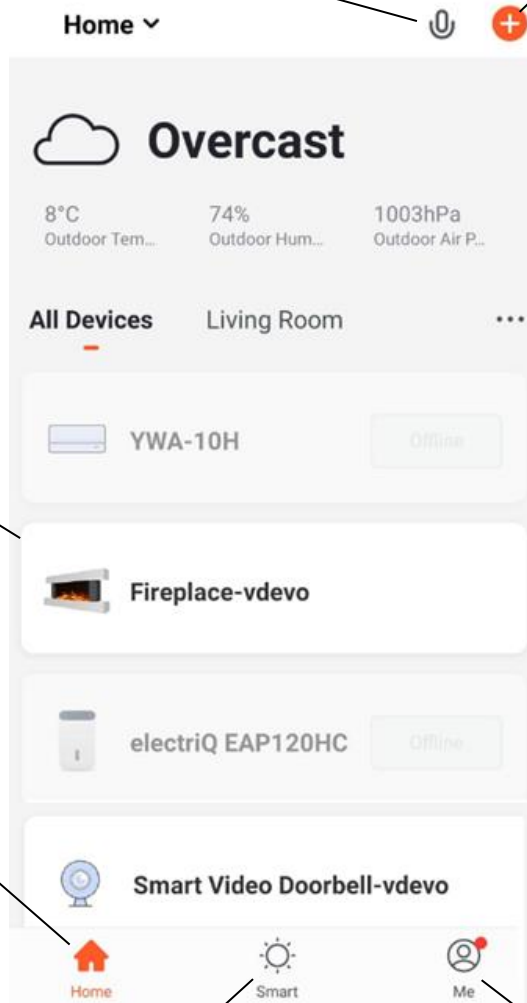

**Name of Heater:** Press to enter the Device Screen

**Home:** Return to home screen from the Smart Scene and Profile screens

**Smart Scene:** Allows you to program intelligent behaviour based on the internal and external environment.

**Profile:** Provides the option for changing settings.

## DEVICE SCREEN

The device screen is the main control screen for the heater, providing access to the controls to amend the functions and settings.

The screenshot shows a mobile application interface for a heater. At the top, there is a 'Device Name' field displaying 'Fireplace-vdevo'. Below this is a status indicator 'C7 | OFF'. The central part of the screen features a large circular temperature display showing '18 °C' and 'Current Temperature -20°C'. Below the temperature display are two large buttons: a minus sign for decreasing the temperature and a plus sign for increasing it, with a 'Set Temperature' label between them. At the bottom, there is a navigation bar with five icons: Power, Flame Colour, Heating, Countdown Timer, and Settings. Lines connect these UI elements to descriptive text blocks around the screen.

**Back:** Returns to the Home Screen

**Device Name:** Edit Name: Use to change the name of the heater. Device information and third part control can also be assessed from this menu.

**Desired Temperature:** Displays what has been set as the target room temperature.

**Current Temperature:** Displays what the current temperature is.

**Increase Desired Temperature**  
Temperature range 15-40°C

**Decrease Desired Temperature**  
Temperature range 15-40°C

**Settings:** Enter the settings menu. You can access temperature scale flame brightness downlights colour and the timer schedule.

**Power:** Use to turn the unit on or off.

**Flame colour:** Use to change the flame colour between C1 and C7.

**Heating:** Used to adjust the heat settings.

**Countdown Timer:** Use to set the countdown timer between 1 and 9 hours.

**NOTE:** Not all Tuya functions will be available, only those applicable. The interface may vary as the application is subject to continual improvement and development.

## DEVICE SETTINGS

**NOTE:** Some Tuya settings may not be applicable to your model.

**HEAT:** To turn the heat on or off.

**FLAME COLOUR:** Click to change the flame colour.

**BACKLIGHT COLOUR:** Click to change the backlight colour.

**FLAME BRIGHTNESS:** Change the flame brightness or turn the flames on or off.

**TIMER:** Schedule a timer to turn the device on or off.

### ADDING A TIMER:

Click add.

Select the time you want the device to turn on or off.

Select 'Repeat' if you would like this to be scheduled for certain days.

You can add a note to name the schedule.

Click 'Switch' to choose if the schedule is to turn on or off the device.

Then click save.

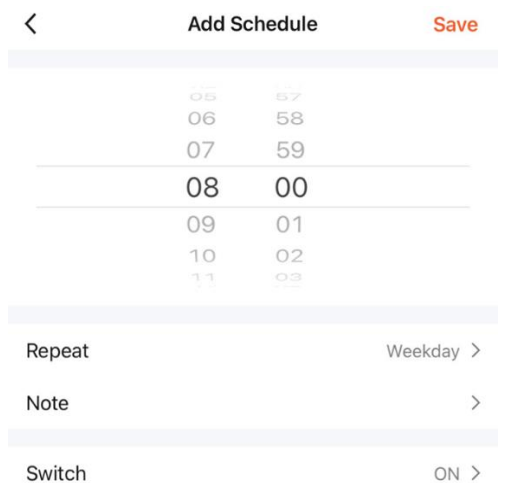
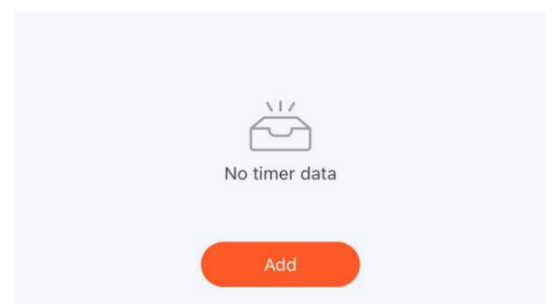
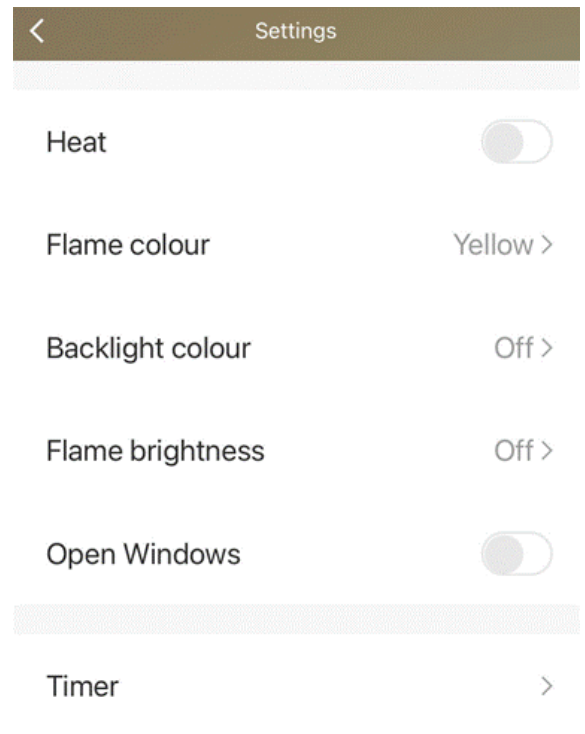

## SMART SCENES

Smart Scenes is a powerful tool that allows the user to customise the operation of the air heater based on conditions within the room and outside influences. This gives the user the option of specifying much more intelligent actions. These are split into two categories: Scene and Automation.

### SCENE

The scene allows for adding a one-touch button to the Home Screen. The button can be used to change several settings in one go and all the unit settings. Several scenes can easily be set up, allowing the user to easily change between several pre-set configurations.

### AUTOMATION

Automation allows an automatic action to be set up for the device. This can be triggered by the Time and various other influences, depending on what other TUYA-enabled devices you have on the network.

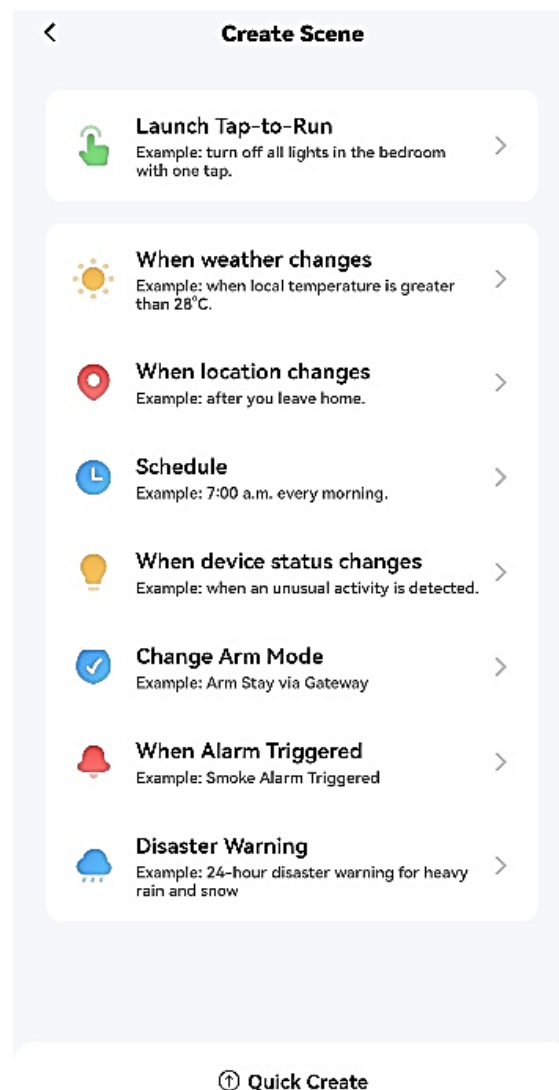

## SETTING UP A SCENE / AUTOMATION

1. Press the **Scene** button at the bottom of the home screen.
2. Press the **Create Scene** button or the **+** icon at the top right corner.
3. Select a scene or automation based on the several options available: [S=Scene, A=Automation]

S	Launch Tap-to-Run	Manually activate a scene with one tap.
A	When the Weather Changes	Trigger actions based on temperature, humidity, or weather (e.g. rain, snow).
A	When Location Changes	Automate devices when arriving at or leaving a location.
A	Schedule	Run actions at specific times or days (e.g. 7:00 AM daily).
A	When the Device Status Changes	Trigger actions when another device changes state (e.g., the heater turns on when the door opens).
A	Change Arm Mode	Automatically change security system mode (Arm, Disarm, Stay).
A	When Alarm Triggered	Activate actions when a device alarm goes off (e.g. smoke alarm).
A	Disaster Warning	Trigger scenes in response to government-issued weather alerts.

4. When creating a scene or automation (except for "Launch Tap-to-Run"), you'll need to set a precondition and define the action to be performed when that condition is met. Actions can include changing the arm mode, switching the appliance on or off, adjusting the temperature, changing the operating mode, enabling or disabling the child lock (if available), activating another scene, sending a notification, or adding a delayed action. You will also need to select the specific appliance that the scene will control.

**NOTE:** The "more settings" button allows you to customise the icon for the scene or automation and the room to which you would like this to apply.

5. Once you have the precondition (If), the function to perform for the selected appliance (Then), and your preferential settings, press the save button, name your Scene or Automation, and confirm.

**NOTE:** Some functions and features under Smart Scenes and Automation may not be available. The application is subject to continual improvement and development.

## PROFILE TAB

### THIRD-PARTY SERVICES

Integrate your devices with voice assistants and automation services for hands-free control and smart scheduling.

Alexa / Google Assistant / SmartThings / IFTTT

- These options let you link your Tuya-compatible devices to third-party platforms for voice commands, routines, or advanced automation workflows.

### HOME MANAGEMENT

Allows you to manage your Tuya smart home environment.

- Create and customise homes
- Add or remove rooms
- Share control of devices with family members or housemates

### MESSAGE CENTER

Shows system and device notifications.

- View alerts from smart devices (e.g., if an alarm is triggered)
- See activity logs or system messages related to your setup

### HELP CENTER

Offers FAQs and basic troubleshooting support.

- Browse frequently asked questions
- Learn how to use features or solve common problems
- Find contact options for support (depending on region)

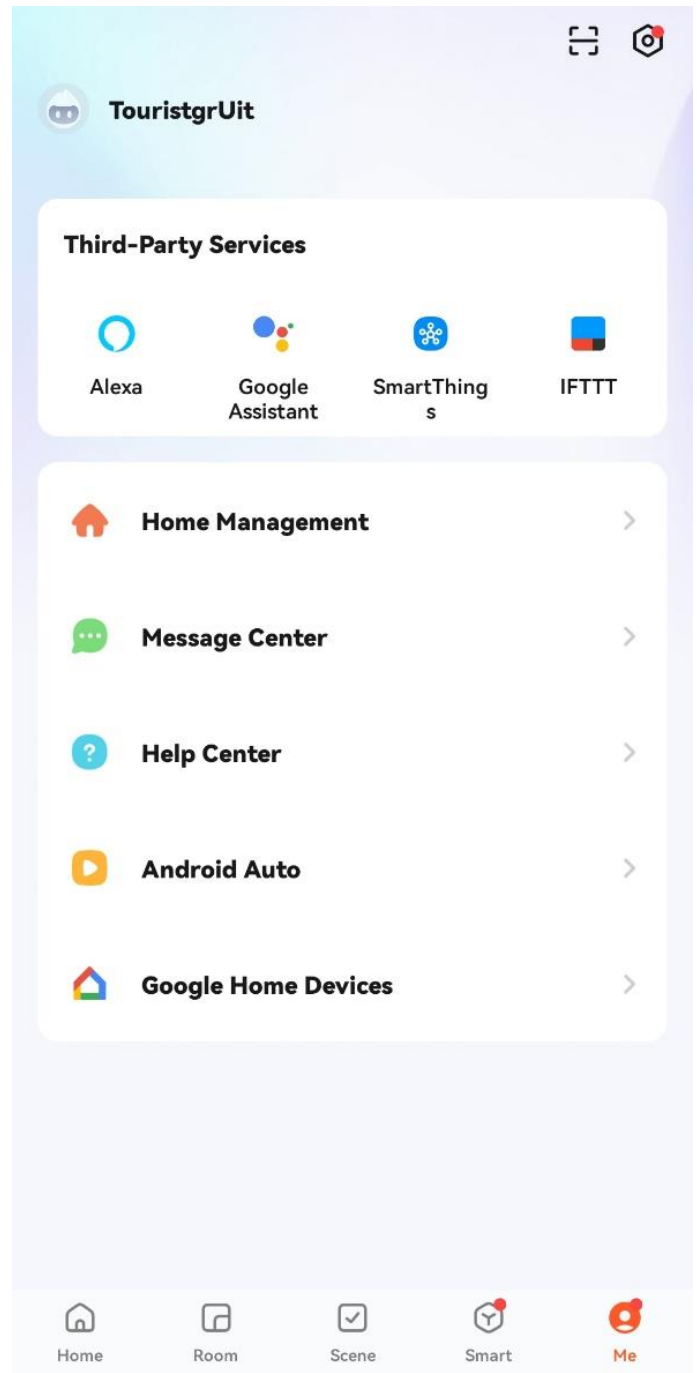

## CARE AND MAINTENANCE

Before cleaning the appliance, the power supply should be disconnected, and the unit should be allowed to cool.

Dust can be removed by lightly wiping the glass surface with a clean, lint-free cloth or paper towel. Use a damp cloth with a good-quality household glass cleaner to remove fingerprints or other marks. The front glass panel should be completely dried before reusing the heater.

### CAUTION:

- Do not use an abrasive cleaner on the glass panels.
- Do not spray liquids directly onto any surface of the unit.
- Do not clean the glass on the inside of the unit, as this may cause damage to the surface.
- The decorative logs may leave a residue on the fuel bed; this is normal and can be cleaned with a soft, damp cloth. Ensure the fire is cool and turned off before cleaning the fuel bed. Ensure any water residue from cleaning has been dried before using the fire.

## REPLACING THE REMOTE BATTERIES

The batteries are not included with your remote. You will need a CR2025 battery.

1. Locate the battery compartment on the back of the remote control.
2. Open the battery cover.
3. Remove the old CR2025 battery.
4. Insert a new CR2025 battery, following the polarity diagram shown inside the compartment.
5. Close the battery cover securely.

### NOTE:

- Do not dispose of the used battery with regular household waste.
- Recycle used batteries at designated recycling points or collection centres in accordance with local regulations.
- Please refer to page 5 regarding battery warnings

## WI-FI CONNECTION TROUBLESHOOTING (TUYA SMART APP)

If you experience difficulties connecting your device to the Tuya Smart app, refer to the table below for common issues and solutions.

ISSUE	POSSIBLE CAUSE	POSSIBLE SOLUTION
<b>Device not found during setup</b>	• Appliance is too far from the router.	• Place the appliance closer to the router during setup.
	• Mobile phone is connected to a 5GHz network.	• Ensure your phone is connected to a 2.4GHz Wi-Fi network.
	• Wi-Fi interference or weak signal.	• Restart your router and phone before retrying.
<b>Wi-Fi indicator not blinking</b>	• Device is not in pairing mode.	• Refer to page 13 for re-pairing your appliance.
<b>Unable to connect to Wi-Fi</b>	<ul style="list-style-type: none"> <li>• Incorrect Wi-Fi password.</li> <li>• Router limitations or signal issues.</li> <li>• Check router settings</li> </ul>	<ul style="list-style-type: none"> <li>• Verify the Wi-Fi password is correct.</li> <li>• Avoid Wi-Fi names (SSID) with special characters.</li> <li>• Ensure your router is not using MAC filtering or firewall blocks.</li> <li>• Place the device closer to the router during setup.</li> <li>• Encryption should be WPA2-PSK, and the authorization type should be set to AES.</li> </ul>
<b>The device was added, but did not respond in the app</b>	<ul style="list-style-type: none"> <li>• Connection was incomplete.</li> <li>• App lacks required permissions.</li> </ul>	<ul style="list-style-type: none"> <li>• Restart the Tuya Smart app and check if the device responds.</li> <li>• Ensure the app has access to <b>Bluetooth, Location, and Nearby Devices</b> in your phone's settings.</li> <li>• Remove and re-add the appliance if needed</li> </ul>
<b>Stuck during pairing</b>	<ul style="list-style-type: none"> <li>• Too many connection attempts in a short time.</li> <li>• Wi-Fi signal interruption.</li> </ul>	<ul style="list-style-type: none"> <li>• Wait at least 10 seconds before restarting the pairing process.</li> <li>• Power cycle the device before retrying.</li> </ul>
<b>Frequent disconnections</b>	<ul style="list-style-type: none"> <li>• Weak Wi-Fi signal.</li> <li>• Network instability.</li> </ul>	<ul style="list-style-type: none"> <li>• Move the router closer or use a Wi-Fi extender.</li> <li>• Keep the device away from thick walls or electronic interference (e.g., microwave ovens).</li> <li>• Ensure the router firmware is up to date.</li> </ul>

**WARNING:** Do not attempt to open, disassemble, or modify the unit. Doing so may result in electric shock, damage to the appliance and voiding of the warranty.

If the above troubleshooting is unable to fix the issue, you may refer to your internet provider for issues concerning network connections and may find suitable fixes for Tuya-related issues or queries on the link: <https://support.tuya.com/en/help>

If issues persist, please do not hesitate to contact customer service.

## TROUBLESHOOTING

Most problems are simple to resolve - please refer to the following table before calling a service engineer:

<b>PROBLEM</b>	<b>POSSIBLE CAUSE</b>	<b>POSSIBLE SOLUTION</b>
The fire has stopped working.	The fire has overheated, the thermal safety device has been activated, or a circuit breaker has tripped.	Check that there is power in the socket where the fire is connected, check the fuse in the plug, check the main power switch on the unit is turned on, and leave for 10 minutes in case of thermal cut-out.
The flame is not moving.	Flame motor defective	Contact the retailer or manufacturer.
The fan is still running when the heating is turned off.	The fan runs for 30 seconds before stopping once the heat has been turned off. This is normal.	

## SERVICING

It is hazardous for anyone other than a qualified service technician to carry out any service or repair operation involving the removal of any components. The lighting for the flame effect is provided by LED bulbs, which are designed to last for the product's life and are not user-replaceable.

A competent person must conduct any servicing or repairs after reading the service manual. Customer service can provide the service manual by emailing [Support@furniture123.co.uk](mailto:Support@furniture123.co.uk).

## WASTE ELECTRICAL RECYCLING

This symbol indicates that this product is classified as electrical or electronic equipment and should not be disposed of with other household waste.

The Waste Electrical and Electrical Equipment (WEEE) Directive has been introduced across the European Union:

- To recycle waste electrical products using the best available recovery and recycling techniques in order to minimise the impact on the environment.
- To treat any hazardous substances.
- To avoid increasing landfills.



WEEE product should be disposed of by handing it over at a designated collection point. Please contact your local authority for more information about where you can drop off your waste product for recycling.

## SUPPORT

For your convenience, please make these simple checks before calling the service line. If the unit still fails to operate, call 0330 390 3062 or complete the online form.

1. Is the unit plugged into the mains?
2. Is the fuse OK?
3. Switch the unit off and wait ten minutes to see if the issue is resolved. Restart the unit.

If the unit still fails to operate, call 0330 390 3062 or log in to your online account to complete an online return.

[www.furniture123.co.uk/content/customer-services](http://www.furniture123.co.uk/content/customer-services)

**Office hours: 9 AM - 5 PM, Monday to Friday**

Buy It Direct

Unit 2A, Trident Business Park,  
Neptune Way, Leeds Road,  
Huddersfield, HD2 1UA.



## TECHNICAL SPECIFICATION

Description of Product	Electric Fireplace Suite with LED Effect Lights	
Rated Voltage	220-240V~	
Rated Frequency	50/60 Hz	
Rated Power	Max 1800W	
Model	AGL087	AGL088
Dimensions (mm)	1300 (W)	1291 (W)
	960 (H)	1186 (H)
	400 (D)	325 (D)
Net Weight	66Kg	65kg

# PRODUCT FICHE

Model Identifier: AGL087 / AGL088					
Item	Symbol	Value	Unit	Item	Unit
<b>Heat Output</b>				<b>Type of heat output/room temperature control (select one)</b>	
Nominal heat output	$P_{nom}$	1.8	kW	single stage heat output and no room temperature control	No
Minimal heat output	$P_{min}$	N/A	kW	two or more manual stages, no room temperature control	No
Maximum continuous heat output	$P_{max}$	1.8	kW	with mechanical thermostat room temperature control	No
<b>Power Consumption</b>				with electronic room temperature control	No
In off mode	$P_o$	N/A	W	with electronic room temperature control plus day timer	No
In standby mode	$P_{on}$	0.26	W	with electronic room temperature control plus week timer	Yes
In idle mode	$P_{idle}$	0.26	W	<b>Other control options (multiple selections possible)</b>	
In network standby	$P_{nsm}$	0.86	W	room temperature control with presence detection	No
Seasonal efficiency		94	%	room temperature control, with open window detection	Yes
<b>Standby mode with display:</b>			N	with distance control option	Yes
				with adaptive start control	No
				with working time limitation	Yes
				with black bulb sensor	Yes
				Self-learning function	No
				Control Accuracy	No
<b>Contact Details</b>	Buy It Direct, Unit 2A, Trident Business Park, Neptune Way, Leeds Road, Huddersfield, HD2 1UA. Buy It Direct, The Black Church, St Mary's Place, Dublin 7.				

## PSTI STATEMENT OF COMPLIANCE

Description: Electric Fireplace Suite with LED Effect Lights - Amberglo

Model Number: AGL087, AGL088

Manufacturer: Furniture123, 2A Trident Business Park, Leeds Road, Huddersfield, HD2 1UA

PSTI Contact: TiSecurity@buyitdirect.co.uk

We have prepared this statement of compliance and can confirm that this product is compliant with the deemed compliance conditions in Schedule 2 of The Product Security and Telecommunications Infrastructure (Security Requirements for Relevant Connectable Products) Regulations 2023.

Duration of security updates: 31/12/2030. This date is correct at the time of printing, but we may extend it. Please visit [www.furniture.co.uk](http://www.furniture.co.uk) for the latest information and details of our PSTI compliance.



Richard Leach

Compliance and Quality Manager, Buy It Direct, Huddersfield

17th July 2025

## EU DECLARATION OF CONFORMITY

Hereby, Furniture123 declares that these towel rails are in compliance with Directive 2014/53/EU.

The full text of the EU Declaration of Conformity is available at the following internet addresses:

<https://furniture123.co.uk/files/DOC/EU/AGL087.pdf>

<https://furniture123.co.uk/files/DOC/EU/AGL088.pdf>

## UK DECLARATION OF CONFORMITY

Hereby, Furniture123 declares that these towel rails are in compliance with the Radio Equipment Regulations 2017.

The full text of the EU Declaration of Conformity is available at the following internet addresses:

<https://furniture123.co.uk/files/DOC/UK/AGL087.pdf>

<https://furniture123.co.uk/files/DOC/UK/AGL088.pdf>